

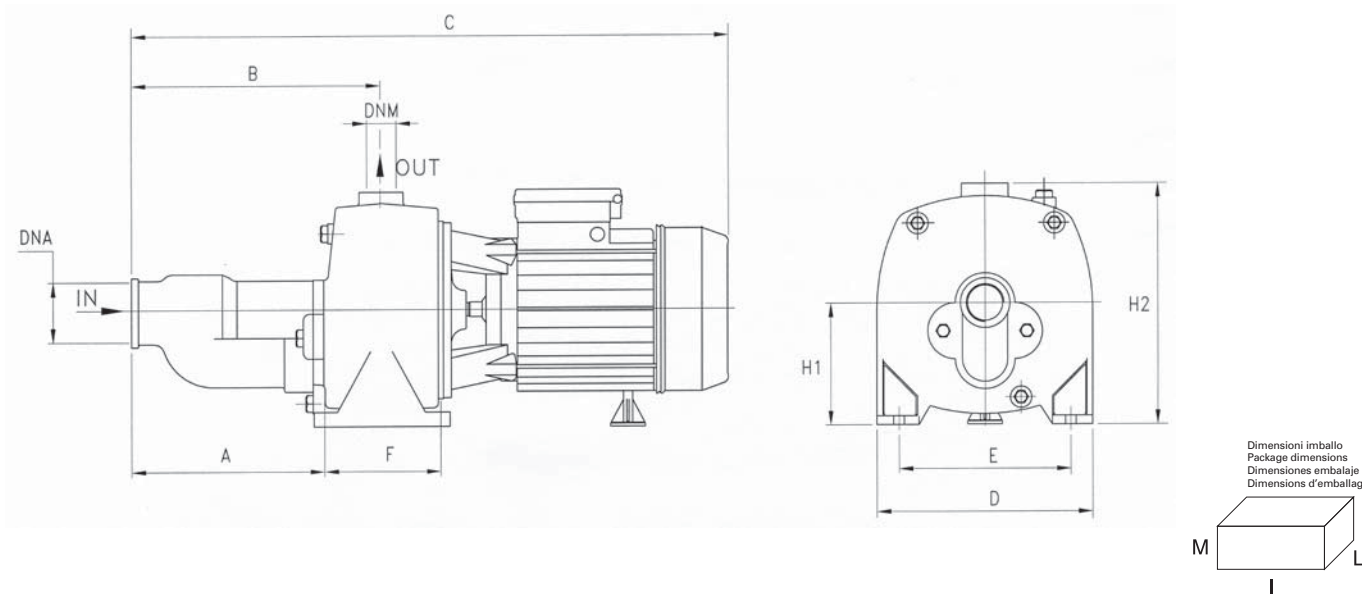

TYPE		P2		P1 (kW)		AMPERE		Q (m³/h - l/min)								
1~	3~	(HP)	(kW)	1~	3~	1~	3~	0	1,2	1,8	3	4,2	5,4	6,6	7,8	8,4
						50 Hz	50 Hz	0	20	30	50	70	90	110	130	140
								H (m)								
CAB 150	CABT 150	1,5	1,1	1,74	1,68	7,9	3,3	61	56,5	54	48	41	32	-	-	-
CAB 200	CABT 200	2	1,5	2,22	2,1	10,3	3,9	62,5	59,5	58	54	49	42,5	34	-	-
CAB 300	CABT 300	3	2,2	2,65	2,5	11,8	4,9	64,5	62	60,5	57	52,5	47	42	35	32



TYPE	DIMENSIONS (mm)													
	A	B	C	D	E	F	H1	H2	DNA	DNM	I	L	M	
CAB 150	204	257	596	220	177	105	112	240	1" 1/2 G	1" G	610	235	275	27.9
CAB 200	204	257	596	220	177	105	112	240	1" 1/2 G	1" G	610	235	275	28.7
CAB 300	204	257	596	220	177	105	112	240	1" 1/2 G	1" G	610	235	275	29.6

AUTOADESCANTI / SELF-PRIMING / AUTOCEBANTES / AUTOMORCANTES